



**THE PROSAFE** System  
Self-supported edge protection

**PROTEKT**<sup>®</sup>  
PROTECT YOUR LIFE | USE IMAGINATION





#### AT 240 (PROSAFE)

Construction standards met by the product:  
PN-EN ISO 14122-3:2005/A1:2010E Part 3  
PN-EN 13374:2005E Class A  
PN-B-02011:1977/Az1:2009P

PROSAFE is a system of module self-supporting railings which do not damage the roofing. It is a system which ensures flexible adjustment to any shape of the roof, allowing protection of almost any surface.





**PROTEKT**<sup>®</sup>

The system of self-supporting railings **PROSAFE** is designed for collective protection of workers working at heights on roofs or on surfaces of non-public facilities. Moreover, there will be a crossbar halfway between the toeboard and the top railing. The system is approved for use on surfaces at a gradient not exceeding 5 degrees, built of bitumen, concrete, asphalt and membrane-lined, as well as combinations of those materials with dry-shake topping of stone and gravel. The system was tested in accordance with the requirements of **EN ISO 14122-3:2001** of standard **EN 13374:2004 – Class A** of protection, which actually means it is capable of counteracting such forces as are exerted on it in the case of: a fall of the person leaning on it, holding to it when walking, stepping up on the railing or falls outside and holding to it. The design isolates the weights from the bearing surface with the use of

special rubber washers made of EPDM, which ensures their resistance to atmospheric conditions and protects the roof against indentation or abrasion, resulting from the effect of high temperatures. The modular structure of the **PROSAFE** system allows assembly without the need for the use of dedicated tools by the workers, who are familiar with the instructions for assembly and disassembly. Prior to assembly it is necessary to check whether the roof is capable of transferring compression loads of 0,68 N/cm<sup>2</sup>. The system allows making gates, passages, spots for snow removal, as well as passages to ladders and other equipment and protection of such passages. The diagram below shows the components of the basic span of the system.

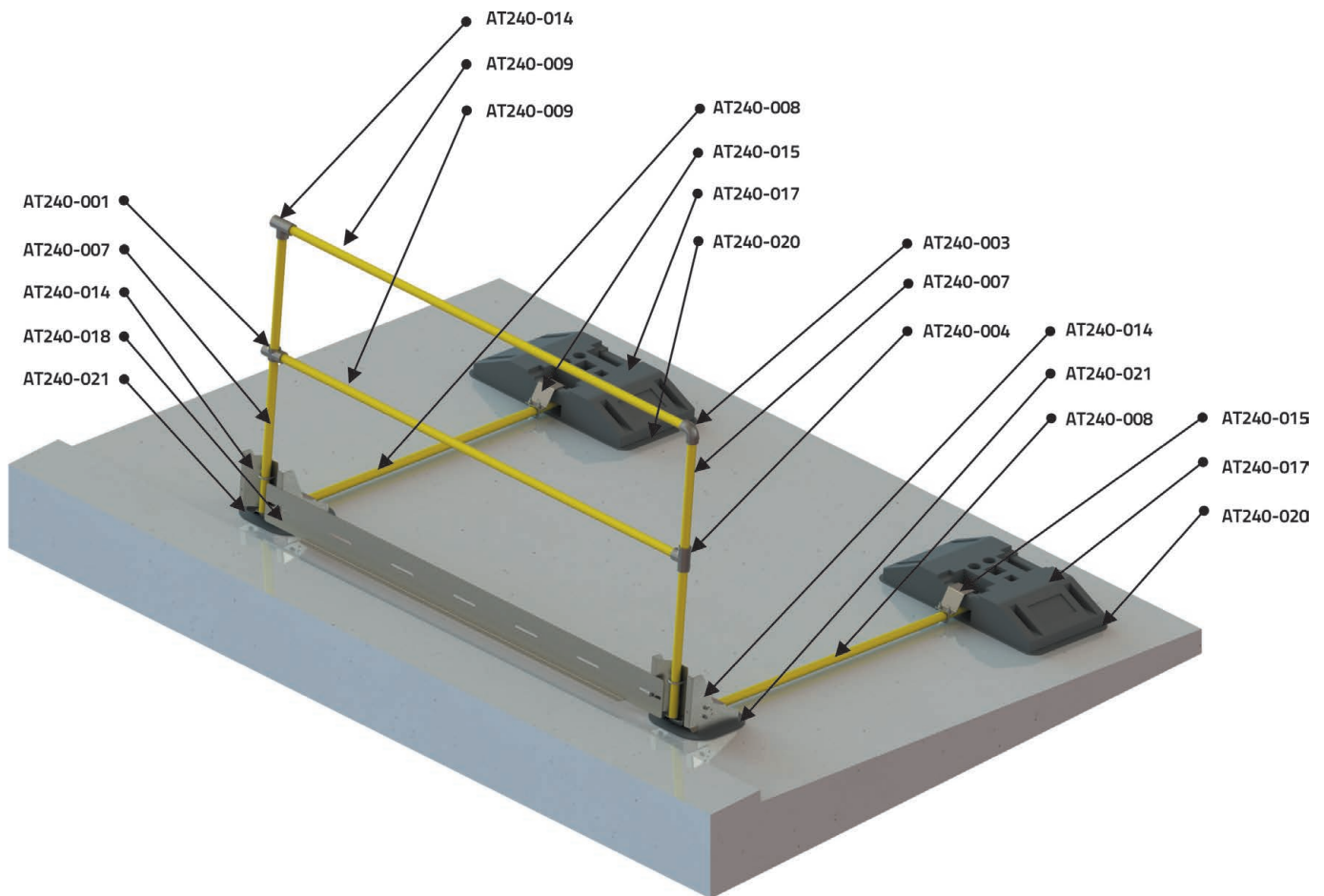

Example of a single span of the barrier including all components.  
The list of components is presented on pages 10 and 11.





The advantage of the modular system of barriers ensures easy transportation of single components and the simplicity of assembly, with the use of only 5 types of connectors made of hot galvanized steel. The heaviest element of the system weighs 24 kg and the longest is 2 m. Where the parapet wall is higher than 150 mm there is no need to use toeboards, thus making assembly yet more simple.







With the use of the full **PROSAFE** system, the worker may safely move around the roof without the need for using the personal protection equipment.



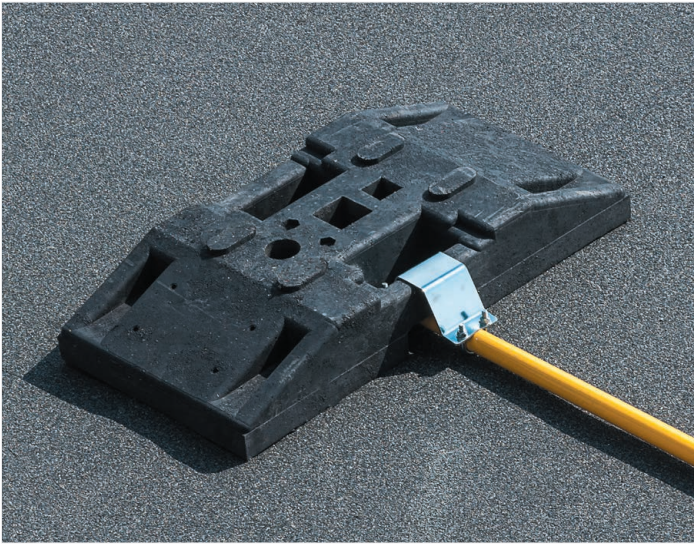

## Weighs

The system of barriers is based on the counterweight principle, provided additionally with an anti-slip layer.

- Weight: 24kg
- Dimensions: 800x400x85
- Ergonomic transport grip
- Colour: black
- Made from recycled materials



## Connection of elements

The system of pipe connectors allows adjustment of the barriers to any shape of the roof, its surface configuration and different levels. The pipe connectors allow making gates, passages, openings and snow discharge zones. Versatility of the system ensures its adaptability to virtually any conditions.



## Aluminium fender beams

Where the parapet wall is lower than 150m, or the barriers are assembled in open spaces, the system allows mounting a toeboard, which will stop the worker's feet from slipping and the tools from rolling off the roof over the edge.



## PROSAFE – example of fencing a roof with a parapet wall

---

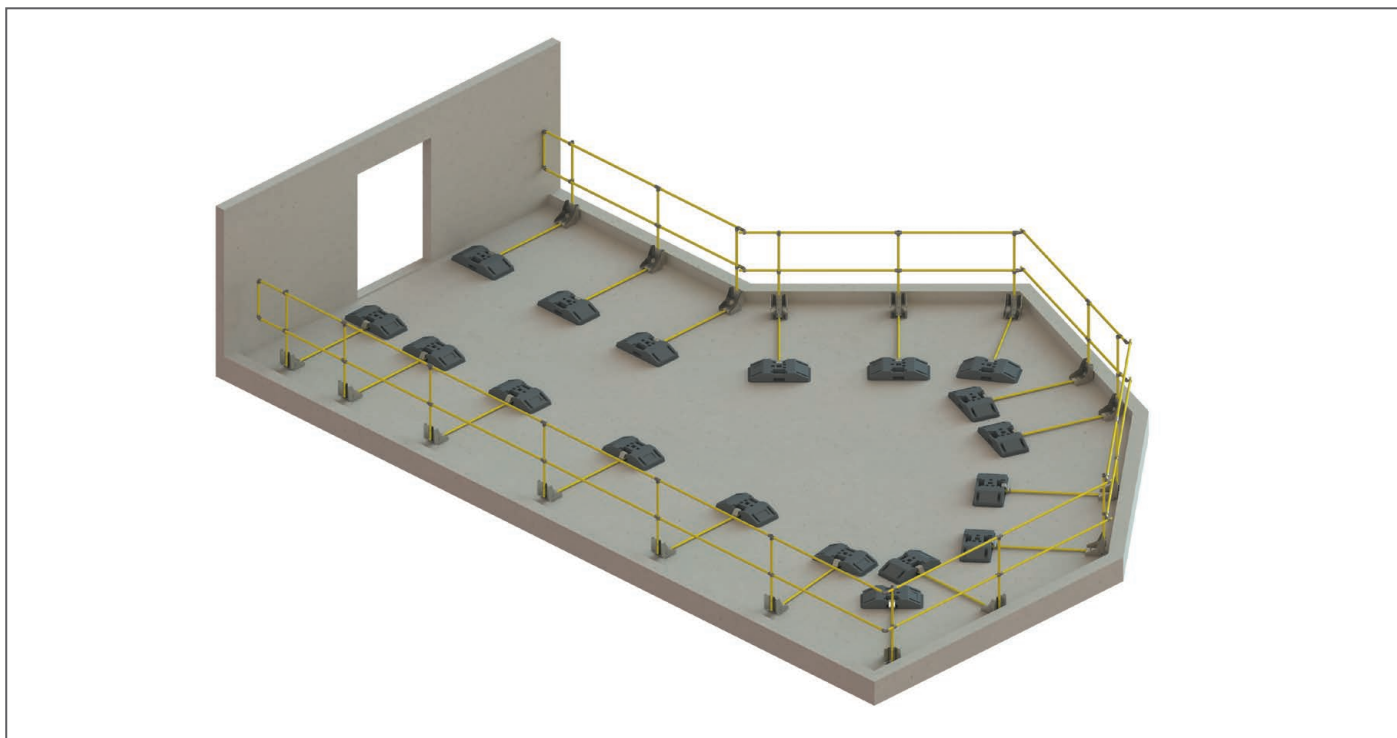

Diagram 1

## PROSAFE – example of the fender beam use – protection of process inlet/outlet openings

---

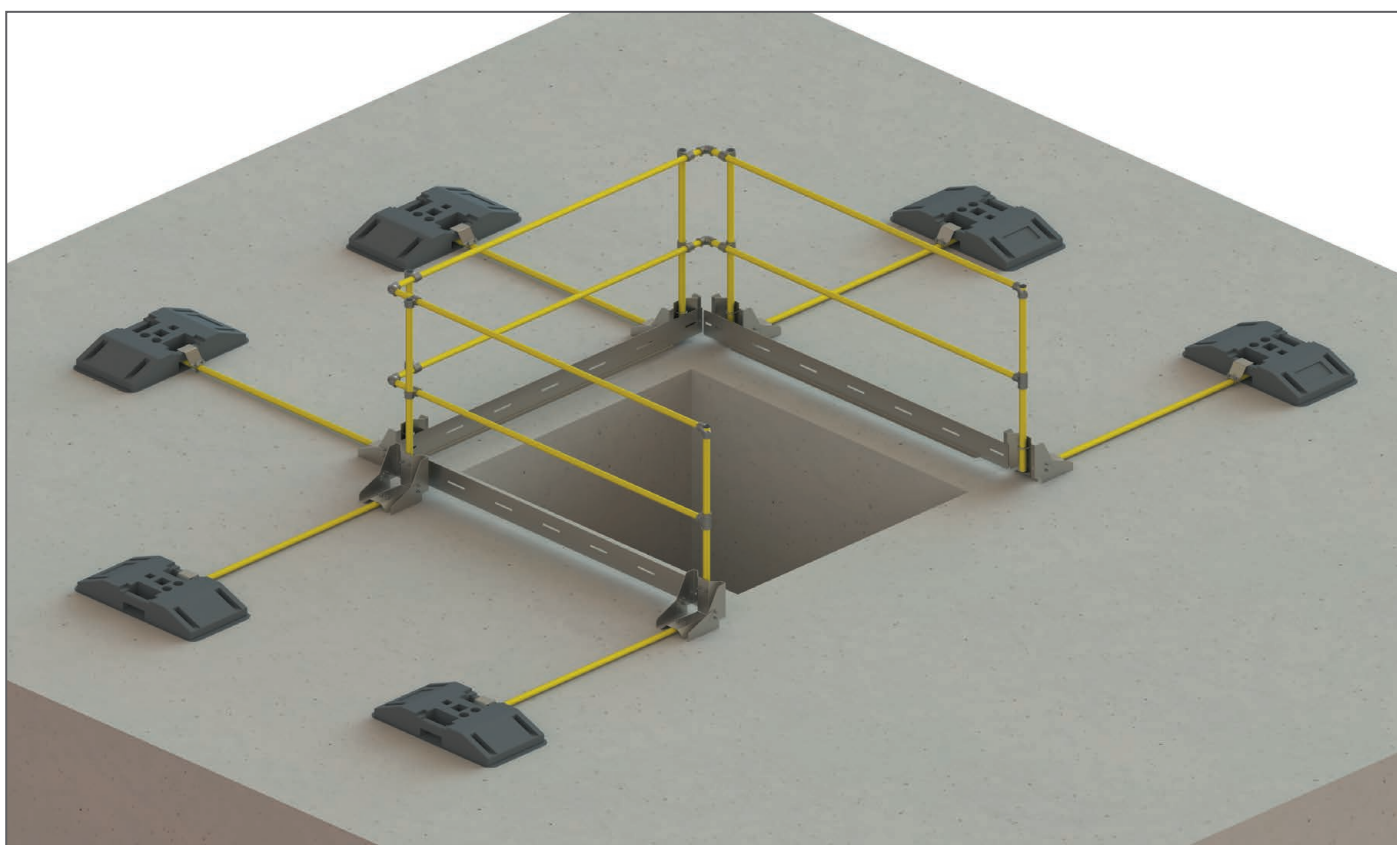

Diagram 2



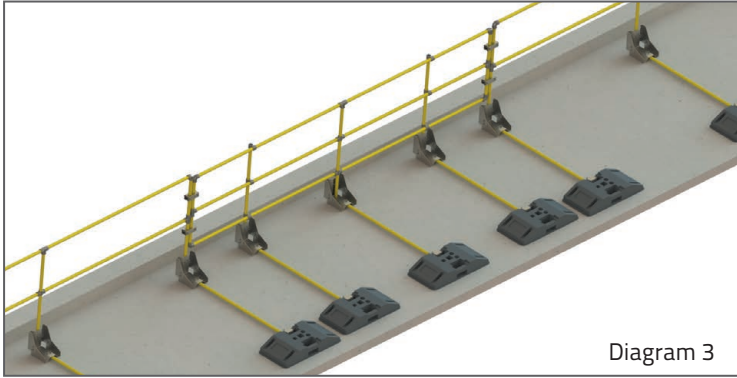

Diagram 3

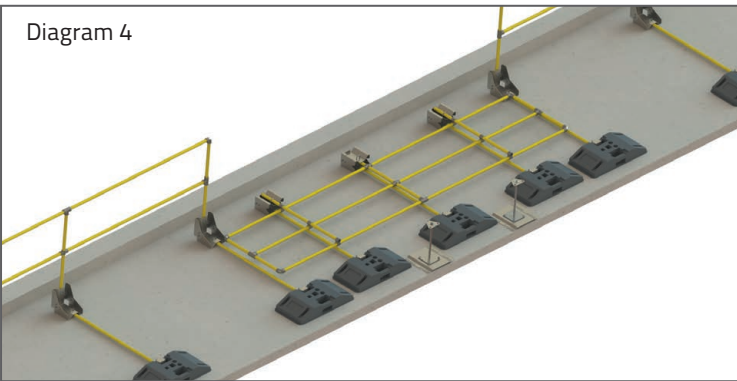

Diagram 4

**The PROSAFE ensures:**

- Ability to make passages and openable gates (Diagram 3&4) and snow discharge zones (Diagram 5&6)
- Possibility of adjustment of railing inclination every 15 degrees within the range of 90 degrees from vertical
- Modular structure and a small number of components
- Possibility of assembling and disassembling the railing segments to assemble at other locations
- Elements which are in contact with the roof are isolated from the base with the use of dedicated washers, and thus resistant to weather conditions
- No interference with the roofing during assembly
- No need for welding, bending and other plumbing service in situ.



Diagram 5



Diagram 6

**Technical data:**

Maximum length of span	2 m
Length of counterweight	1,5 m
Height of railing	1,1 m
Max space between handrails	0,5 m
Mass of counterweight	24 kg
Length of the longest element	2 m
Minimum compression strength of the base	0,6 kN/m <sup>2</sup>
Design load applied to top handrail	300 N/m
Diameter of handrail and posts	33,7 mm

Possible use **on many** types of surfaces



Assembly **does not require** any special tools nor qualifications.





## Components of the system – pipe connections



**Elbow pipe**  
Ref. No.: AT240-003



**Straight pipe**  
Ref. No.: AT240-002



**T-connection**  
Ref. No.: AT240-004



**Pipe cross**  
Ref. No.: AT240-001



**Hinged pipe connector**  
Ref. No.: AT240-005

Pipe connectors are made of cast steel, hot galvanized for protection against corrosion, under PN-EN 1562 and PN-EN 1563. Connector fixing bolts are made of stainless steel, thus ensuring good anti-corrosion protection against weather conditions.

Assembly of connections with the use of a **single** Allen wrench.



## System components - railing



Catalogue number	Length
Ref. No.: AT240-011	0,35 m
Ref. No.: AT240-012	0,5 m
Ref. No.: AT240-013	0,75 m
Ref. No.: AT240-007	1,1 m
Ref. No.: AT240-008	1,5 m
Ref. No.: AT240-009	2 m

The railing is made of steel pipes with internal diameter of 33.7mm and a 2 mm thick wall, in accordance with PN-EN 39, protected against corrosion by powder painting. Each pipe has a plug preventing water flow through the pipe, additionally protecting it against weather conditions.

Available in **all colours** of the RAL palette.





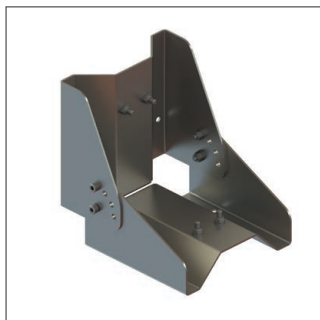

**Basis of barrier**

Ref. No.: AT240-014  
Material: Hot galvanized steel

Ref. No.: AT240-014i  
Material: Stainless steel

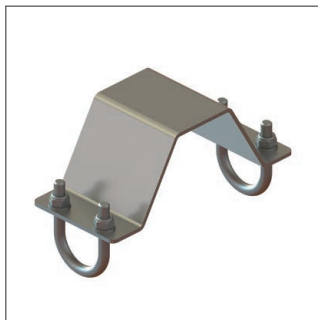

**Weight fastening element**

Ref. No.: AT240-015  
Material: Hot galvanized steel

Ref. No.: AT240-015i  
Material: Stainless steel



**External pipe connector**

Ref. No.: AT240-016  
Material: Stainless steel

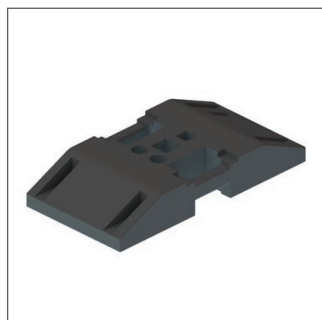

**Barrier weight**

Ref. No.: AT240-017  
Material: Rubber and plastic composite

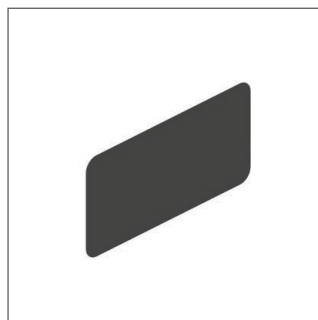

**Rubber mass washer**

Ref. No.: AT240-020  
Material: EPDM rubber  
Thickness: 4 mm

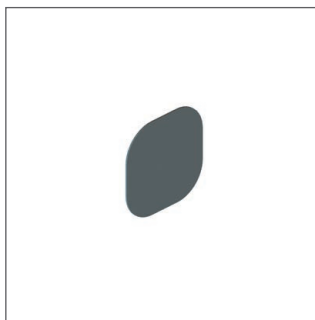

**Rubber base washer**

Ref. No.: AT240-021  
Material: EPDM rubber  
Thickness: 4 mm



**Toeboard 2 m**

Ref. No.: AT240-018  
Material: Hot galvanized steel

Ref. No.: AT240-018a  
Material: Aluminium

Ref. No.: AT240-018i  
Material: Stainless steel

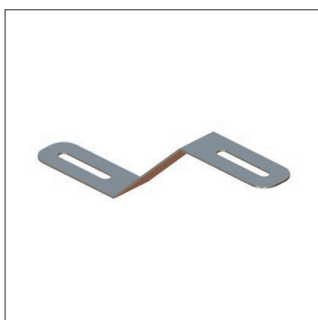

**Toeboard connector**

Ref. No.: AT240-019i  
Material: Stainless steel

Assembly of the remaining elements  
with the use of a **single** flat wrench.







# PROTEKT

Starorudzka 9  
93-403 Łódź  
POLAND

[www.protekt.com.pl](http://www.protekt.com.pl)  
[info@protekt.com.pl](mailto:info@protekt.com.pl)  
phone +48 42 29 29 500  
phone +48 42 680 20 83  
fax: +48 42 680 20 93

**PROTEKT**<sup>®</sup>  
PROTECT YOUR LIFE | USE IMAGINATION